

DATA SHEET

80C552/83C552

Single-chip 8-bit microcontroller with
10-bit A/D, capture/compare timer,
high-speed outputs, PWM

Product data
Supersedes data of 1998 Aug 13

2002 Sep 03

Single-chip 8-bit microcontroller with 10-bit A/D, capture/compare timer, high-speed outputs, PWM

80C552/83C552

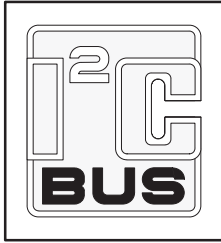

DESCRIPTION

The 80C552/83C552 (hereafter generically referred to as 8XC552) Single-Chip 8-Bit Microcontroller is manufactured in an advanced CMOS process and is a derivative of the 80C51 microcontroller family. The 8XC552 has the same instruction set as the 80C51. Three versions of the derivative exist:

- 83C552—8 kbytes mask programmable ROM
- 80C552—ROMless version of the 83C552
- 87C552—8 kbytes EPROM (described in a separate chapter)

The 8XC552 contains a non-volatile 8k × 8 read-only program memory (83C552), a volatile 256 × 8 read/write data memory, five 8-bit I/O ports, one 8-bit input port, two 16-bit timer/event counters (identical to the timers of the 80C51), an additional 16-bit timer coupled to capture and compare latches, a 15-source, two-priority-level, nested interrupt structure, an 8-input ADC, a dual DAC pulse width modulated interface, two serial interfaces (UART and I²C-bus), a “watchdog” timer and on-chip oscillator and timing circuits. For systems that require extra capability, the 8XC552 can be expanded using standard TTL compatible memories and logic.

In addition, the 8XC552 has two software selectable modes of power reduction—idle mode and power-down mode. The idle mode freezes the CPU while allowing the RAM, timers, serial ports, and interrupt system to continue functioning. The power-down mode saves the RAM contents but freezes the oscillator, causing all other chip functions to be inoperative.

The device also functions as an arithmetic processor having facilities for both binary and BCD arithmetic plus bit-handling capabilities. The instruction set consists of over 100 instructions: 49 one-byte, 45 two-byte, and 17 three-byte. With a 16 MHz (24 MHz) crystal, 58% of the instructions are executed in 0.75 μs (0.5 μs) and 40% in 1.5 μs (1 μs). Multiply and divide instructions require 3 μs (2 μs).

FEATURES

- 80C51 central processing unit
- 8k × 8 ROM expandable externally to 64 kbytes
- ROM code protection
- An additional 16-bit timer/counter coupled to four capture registers and three compare registers
- Two standard 16-bit timer/counters
- 256 × 8 RAM, expandable externally to 64 kbytes
- Capable of producing eight synchronized, timed outputs
- A 10-bit ADC with eight multiplexed analog inputs
- Two 8-bit resolution, pulse width modulation outputs
- Five 8-bit I/O ports plus one 8-bit input port shared with analog inputs
- I²C-bus serial I/O port with byte oriented master and slave functions
- Full-duplex UART compatible with the standard 80C51
- On-chip watchdog timer
- Three speed ranges:
 - 3.5 to 16 MHz
 - 3.5 to 24 MHz (ROM, ROMless only)
- Three operating ambient temperature ranges:
 - P83C552xBx: 0 °C to +70 °C
 - P83C552xFx: -40 °C to +85 °C (XTAL frequency max. 24 MHz)
 - P83C552xHx: -40 °C to +125 °C (XTAL frequency max. 16 MHz)

LOGIC SYMBOL

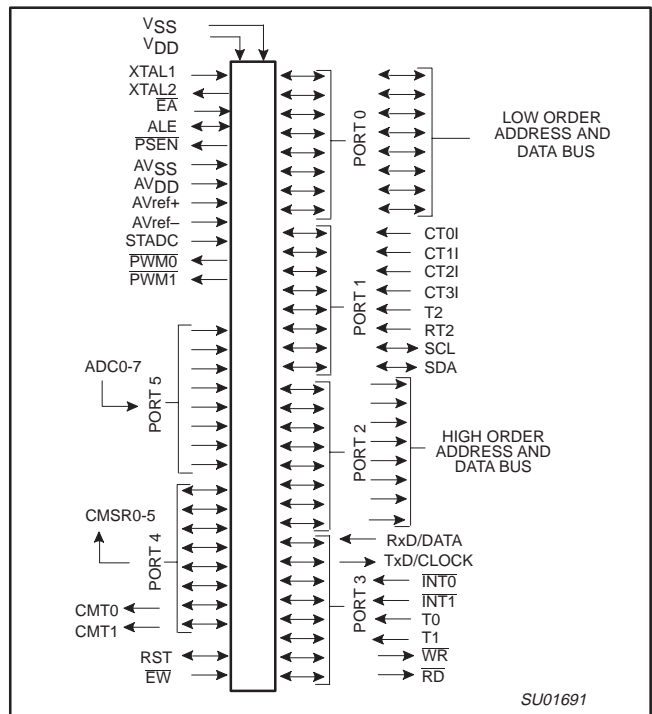

Single-chip 8-bit microcontroller with 10-bit A/D, capture/compare timer, high-speed outputs, PWM

80C552/83C552

PIN CONFIGURATIONS

Plastic Leaded Chip Carrier

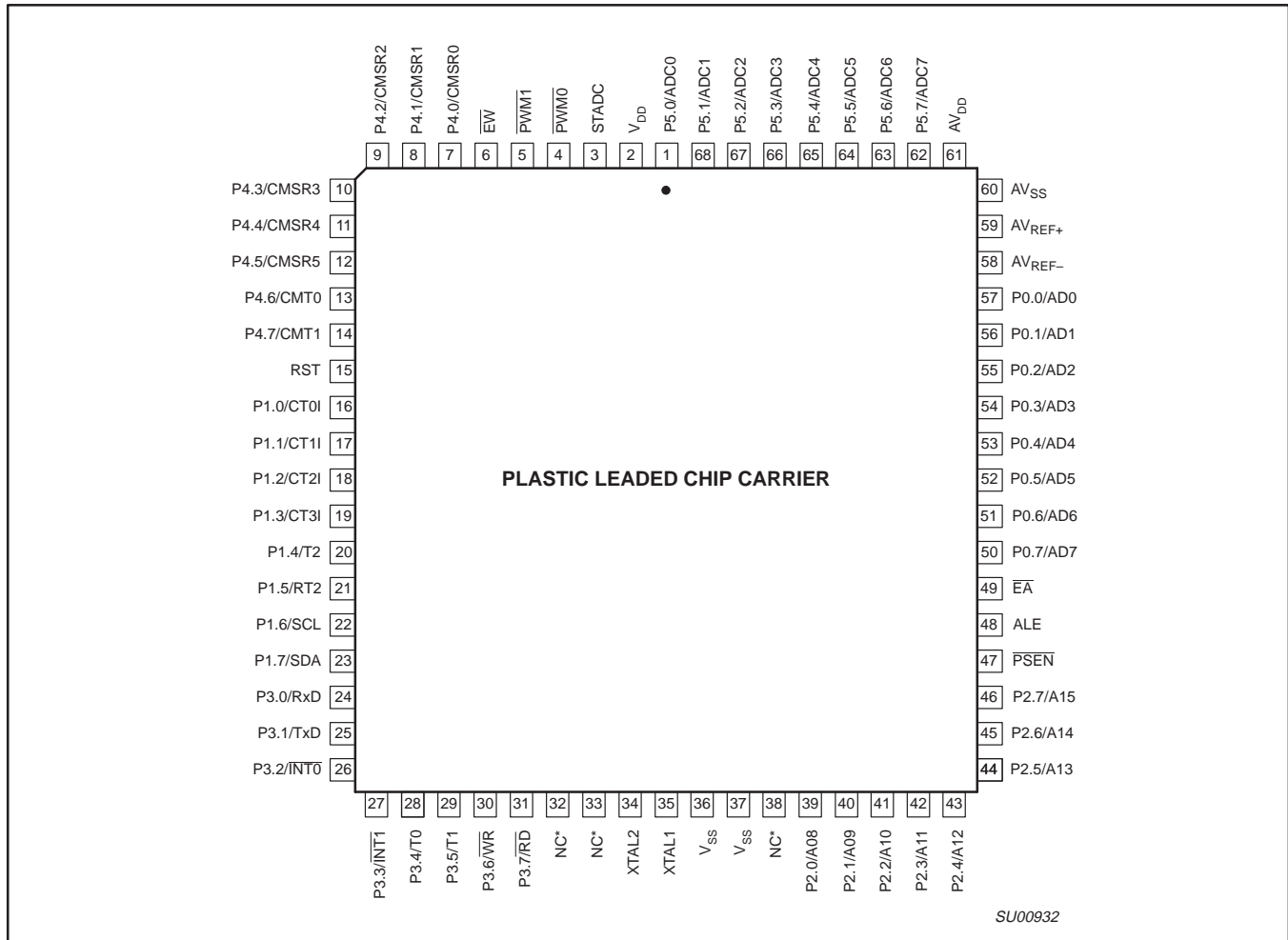

* Do not connect.

Single-chip 8-bit microcontroller with 10-bit A/D, capture/compare timer, high-speed outputs, PWM

80C552/83C552

Plastic Quad Flat Pack

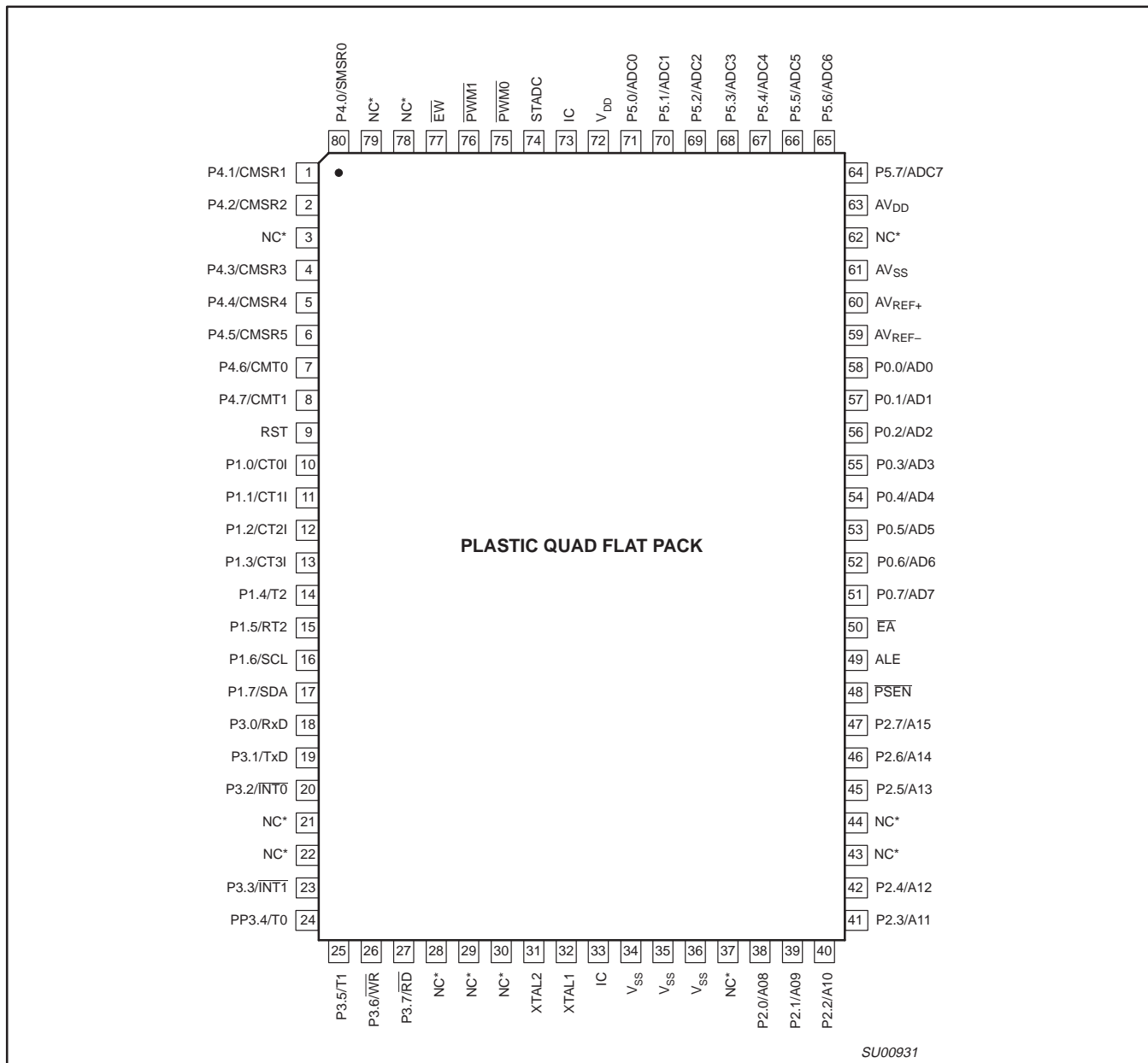

* Do not connect.
 IC = Internally connected (do not use).

Single-chip 8-bit microcontroller with 10-bit A/D, capture/compare timer, high-speed outputs, PWM

80C552/83C552

BLOCK DIAGRAM

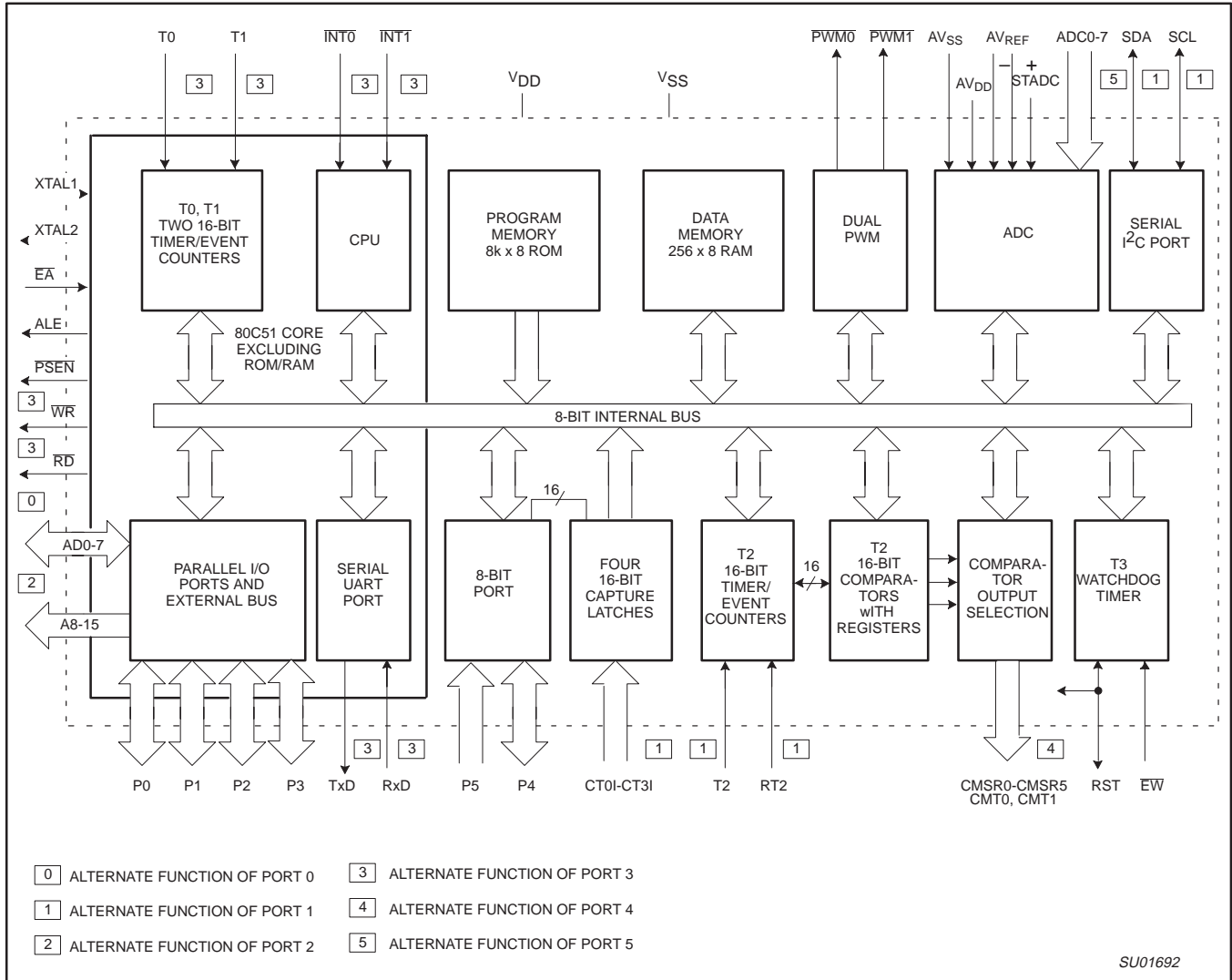

Single-chip 8-bit microcontroller with 10-bit A/D, capture/compare timer, high-speed outputs, PWM

80C552/83C552

ORDERING INFORMATION

PHILIPS PART ORDER NUMBER PART MARKING		DRAWING NUMBER	TEMPERATURE (°C) AND PACKAGE	FREQ (MHz)
ROMless	ROM ¹			
P80C552EBA	P83C552EBA/xxx	SOT188-2	0 to +70, Plastic Leaded Chip Carrier	16
P80C552EBB	P83C552EBB/xxx	SOT318-2	0 to +70, Plastic Quad Flat Pack	16
P80C552EFA	P83C552EFA/xxx	SOT188-2	-40 to +85, Plastic Leaded Chip Carrier	16
P80C552EFB	P83C552EFB/xxx	SOT318-2	-40 to +85, Plastic Quad Flat Pack	16
P80C552EHA	P83C552EHA/xxx	SOT188-2	-40 to +125, Plastic Leaded Chip Carrier	16
P80C552EHB	P83C552EHB/xxx	SOT318-2	-40 to +125, Plastic Quad Flat Pack	16
P80C552IBA	P83C552IBA/xxx	SOT188-2	0 to +70, Plastic Leaded Chip Carrier	24
P80C552IBB	P83C552IBB/xxx	SOT318-2	0 to +70, Plastic Quad Flat Pack	24
P80C552IFA	P83C552IFA/xxx	SOT188-2	-40 to +85, Plastic Leaded Chip Carrier	24
P80C552IFB	P83C552IFB/xxx	SOT318-2	-40 to +85, Plastic Quad Flat Pack	24

NOTE:

- xxx denotes the ROM code number.
- For EPROM device specification, refer to 87C552 datasheet.

Single-chip 8-bit microcontroller with 10-bit A/D, capture/compare timer, high-speed outputs, PWM

80C552/83C552

PIN DESCRIPTION

MNEMONIC	PIN NO.		TYPE	NAME AND FUNCTION
	PLCC	QFP		
V _{DD}	2	72	I	Digital Power Supply: +5 V power supply pin during normal operation, idle and power-down mode.
STADC	3	74	I	Start ADC Operation: Input starting analog to digital conversion (ADC operation can also be started by software). This pin must not float.
PWM0	4	75	O	Pulse Width Modulation: Output 0.
PWM1	5	76	O	Pulse Width Modulation: Output 1.
EW	6	77	I	Enable Watchdog Timer: Enable for T3 watchdog timer and disable power-down mode. This pin must not float.
P0.0-P0.7	57-50	58-51	I/O	Port 0: Port 0 is an 8-bit open-drain bidirectional I/O port. Port 0 pins that have 1s written to them float and can be used as high-impedance inputs. Port 0 is also the multiplexed low-order address and data bus during accesses to external program and data memory. In this application it uses strong internal pull-ups when emitting 1s.
P1.0-P1.7	16-23	10-17	I/O	Port 1: 8-bit I/O port. Alternate functions include: (P1.0-P1.5): Quasi-bidirectional port pins. (P1.6, P1.7): Open drain port pins. CT0I-CT3I (P1.0-P1.3): Capture timer input signals for timer T2. T2 (P1.4): T2 event input. RT2 (P1.5): T2 timer reset signal. Rising edge triggered. SCL (P1.6): Serial port clock line I ² C-bus. SDA (P1.7): Serial port data line I ² C-bus. Port 1 is also used to input the lower order address byte during EPROM programming and verification. A0 is on P1.0, etc.
	16-21	10-15	I/O	
	22-23	16-17	I/O	
	16-19	10-13	I	
	20	14	I	
	21	15	I	
	22	16	I/O	
	23	17	I/O	
P2.0-P2.7	39-46	38-42, 45-47	I/O	Port 2: 8-bit quasi-bidirectional I/O port. Alternate function: High-order address byte for external memory (A08-A15).
P3.0-P3.7	24-31	18-20, 23-27	I/O	Port 3: 8-bit quasi-bidirectional I/O port. Alternate functions include: RxD (P3.0): Serial input port. TxD (P3.1): Serial output port. INT0 (P3.2): External interrupt. INT1 (P3.3): External interrupt. T0 (P3.4): Timer 0 external input. T1 (P3.5): Timer 1 external input. WR (P3.6): External data memory write strobe. RD (P3.7): External data memory read strobe.
	24	18		
	25	19		
	26	20		
	27	23		
	28	24		
	29	25		
	30	26		
	31	27		
P4.0-P4.7	7-14	80, 1-2 4-8	I/O	Port 4: 8-bit quasi-bidirectional I/O port. Alternate functions include: CMSR0-CMSR5 (P4.0-P4.5): Timer T2 compare and set/reset outputs on a match with timer T2. CMT0, CMT1 (P4.6, P4.7): Timer T2 compare and toggle outputs on a match with timer T2.
	7-12	80, 1-2 4-6	O	
	13, 14	7, 8	O	
P5.0-P5.7	68-62, 1	71-64,	I	Port 5: 8-bit input port. ADC0-ADC7 (P5.0-P5.7): Alternate function: Eight input channels to ADC.
RST	15	9	I/O	Reset: Input to reset the 8XC552. It also provides a reset pulse as output when timer T3 overflows.
XTAL1	35	32	I	Crystal Input 1: Input to the inverting amplifier that forms the oscillator, and input to the internal clock generator. Receives the external clock signal when an external oscillator is used.
XTAL2	34	31	O	Crystal Input 2: Output of the inverting amplifier that forms the oscillator. Left open-circuit when an external clock is used.

Single-chip 8-bit microcontroller with 10-bit A/D, capture/compare timer, high-speed outputs, PWM

80C552/83C552

PIN DESCRIPTION (Continued)

MNEMONIC	PIN NO.		TYPE	NAME AND FUNCTION
	PLCC	QFP		
V _{SS}	36, 37	34-36	I	Two Digital ground pins.
PSEN	47	48	O	Program Store Enable: Active-low read strobe to external program memory.
ALE	48	49	O	Address Latch Enable: Latches the low byte of the address during accesses to external memory. It is activated every six oscillator periods. During an external data memory access, one ALE pulse is skipped. ALE can drive up to eight LS TTL inputs and handles CMOS inputs without an external pull-up.
E \bar{A}	49	50	I	External Access: When E \bar{A} is held at TTL level high, the CPU executes out of the internal program ROM provided the program counter is less than 8192. When E \bar{A} is held at TTL low level, the CPU executes out of external program memory. E \bar{A} is not allowed to float.
AV _{REF-}	58	59	I	Analog to Digital Conversion Reference Resistor: Low-end.
AV _{REF+}	59	60	I	Analog to Digital Conversion Reference Resistor: High-end.
AV _{SS}	60	61	I	Analog Ground
AV _{DD}	61	63	I	Analog Power Supply

NOTE:

- To avoid "latch-up" effect at power-on, the voltage on any pin at any time must not be higher or lower than V_{DD} + 0.5 V or V_{SS} - 0.5 V, respectively.

OSCILLATOR CHARACTERISTICS

XTAL1 and XTAL2 are the input and output, respectively, of an inverting amplifier. The pins can be configured for use as an on-chip oscillator, as shown in the logic symbol, page 2.

To drive the device from an external clock source, XTAL1 should be driven while XTAL2 is left unconnected. There are no requirements on the duty cycle of the external clock signal, because the input to the internal clock circuitry is through a divide-by-two flip-flop. However, minimum and maximum high and low times specified in the data sheet must be observed.

RESET

A reset is accomplished by holding the RST pin high for at least two machine cycles (24 oscillator periods), while the oscillator is running. To insure a good power-on reset, the RST pin must be high long enough to allow the oscillator time to start up (normally a few milliseconds) plus two machine cycles. At power-on, the voltage on V_{DD} and RST must come up at the same time for a proper start-up.

IDLE MODE

In the idle mode, the CPU puts itself to sleep while some of the on-chip peripherals stay active. The instruction to invoke the idle mode is the last instruction executed in the normal operating mode before the idle mode is activated. The CPU contents, the on-chip RAM, and all of the special function registers remain intact during this mode. The idle mode can be terminated either by any enabled interrupt (at which time the process is picked up at the interrupt

service routine and continued), or by a hardware reset which starts the processor in the same manner as a power-on reset.

POWER-DOWN MODE

In the power-down mode, the oscillator is stopped and the instruction to invoke power-down is the last instruction executed. Only the contents of the on-chip RAM are preserved. A hardware reset is the only way to terminate the power-down mode. The control bits for the reduced power modes are in the special function register PCON. Table 1 shows the state of the I/O ports during low current operating modes.

ROM CODE PROTECTION (83C552)

The 83C552 has an additional security feature. ROM code protection may be selected by setting a mask-programmable security bit (i.e., user dependent). This feature may be requested during ROM code submission. When selected, the ROM code is protected and cannot be read out at any time by any test mode or by any instruction in the external program memory space.

The MOVC instructions are the only instructions that have access to program code in the internal or external program memory. The E \bar{A} input is latched during RESET and is "don't care" after RESET (also if the security bit is not set). This implementation prevents reading internal program code by switching from external program memory to internal program memory during a MOVC instruction or any other instruction that uses immediate data.

Table 1. External Pin Status During Idle and Power-Down Modes

MODE	PROGRAM MEMORY	ALE	PSEN	PORT 0	PORT 1	PORT 2	PORT 3	PORT 4	PWM0/PWM1
Idle	Internal	1	1	Data	Data	Data	Data	Data	1
Idle	External	1	1	Float	Data	Address	Data	Data	1
Power-down	Internal	0	0	Data	Data	Data	Data	Data	1
Power-down	External	0	0	Float	Data	Data	Data	Data	1

Single-chip 8-bit microcontroller with 10-bit A/D, capture/compare timer, high-speed outputs, PWM

80C552/83C552

Serial Control Register (S1CON) – See Table 2

S1CON (D8H)	CR2	ENS1	STA	STO	SI	AA	CR1	CR0
-------------	-----	------	-----	-----	----	----	-----	-----

Bits CR0, CR1 and CR2 determine the serial clock frequency that is generated in the master mode of operation.

Table 2. Serial Clock Rates

CR2	CR1	CR0	BIT FREQUENCY (kHz) AT f _{OSC}				f _{OSC} DIVIDED BY
			6 MHz	12 MHz	16 MHz	24 MHz ²	
0	0	0	23	47	62.5	94	256
0	0	1	27	54	71	107 ¹	224
0	1	0	31	63	83.3	125 ¹	192
0	1	1	37	75	100	150 ¹	160
1	0	0	6.25	12.5	17	25	960
1	0	1	50	100	133 ¹	200 ¹	120
1	1	0	100	200	267 ¹	400 ¹	60
1	1	1	0.24 < 62.5 0 < 255	0.49 < 62.5 0 < 254	0.65 < 55.6 0 < 253	0.98 < 50.0 0 < 251	96 × (256 – (reload value Timer 1)) reload value Timer 1 in Mode 2.

NOTES:

1. These frequencies exceed the upper limit of 100kHz of the I²C-bus specification and cannot be used in an I²C-bus application.
2. At f_{OSC} = 24 MHz the maximum I²C bus rate of 100kHz cannot be realized due to the fixed divider rates.

ABSOLUTE MAXIMUM RATINGS^{1, 2, 3}

PARAMETER	RATING	UNIT
Storage temperature range	-65 to +150	°C
Voltage on any other pin to V _{SS}	-0.5 to +6.5	V
Input, output DC current on any single I/O pin	5.0	mA
Power dissipation (based on package heat transfer limitations, not device power consumption)	1.0	W

NOTES:

1. Stresses above those listed under Absolute Maximum Ratings may cause permanent damage to the device. This is a stress rating only and functional operation of the device at these or any conditions other than those described in the AC and DC Electrical Characteristics section of this specification is not implied.
2. This product includes circuitry specifically designed for the protection of its internal devices from the damaging effects of excessive static charge. Nonetheless, it is suggested that conventional precautions be taken to avoid applying greater than the rated maxima.
3. Parameters are valid over operating temperature range unless otherwise specified. All voltages are with respect to V_{SS} unless otherwise noted.

DEVICE SPECIFICATIONS

TYPE	SUPPLY VOLTAGE (V)		FREQUENCY (MHz)		TEMPERATURE RANGE (°C)
	MIN	MAX	MIN	MAX	
P83(0)C552EBx	4.5	5.5	3.5	16	0 to +70
P83(0)C552EFx	4.5	5.5	3.5	16	-40 to +85
P83(0)C552EHx	4.5	5.5	3.5	16	-40 to +125
P83(0)C552IBx	4.5	5.5	3.5	24	0 to +70
P83(0)C552IFx	4.5	5.5	3.5	24	-40 to +85

Single-chip 8-bit microcontroller with 10-bit A/D, capture/compare timer, high-speed outputs, PWM

80C552/83C552

DC ELECTRICAL CHARACTERISTICS

 $V_{SS}, AV_{SS} = 0\text{ V}; V_{DD}, AV_{DD} = 5\text{ V} \pm 10\%$

SYMBOL	PARAMETER	TEST CONDITIONS	LIMITS		UNIT
			MIN	MAX	
I _{DD}	Supply current operating:	See notes 1 and 2			
	P83(0)C552EBx	f _{OSC} = 16 MHz		45	mA
	P83(0)C552EFx	f _{OSC} = 16 MHz		45	mA
	P83(0)C552EHx	f _{OSC} = 16 MHz		40	mA
	P83(0)C552IBx P83(0)C552IFx	f _{OSC} = 24 MHz f _{OSC} = 24 MHz		55 55	mA mA
I _{ID}	Idle mode:	See notes 1 and 3			
	P83(0)C552EBx	f _{OSC} = 16 MHz		10	mA
	P83(0)C552EFx	f _{OSC} = 16 MHz		10	mA
	P83(0)C552EHx	f _{OSC} = 16 MHz		9	mA
	P83(0)C552IBx P83(0)C552IFx	f _{OSC} = 24 MHz f _{OSC} = 24 MHz		12.5 12.5	mA mA
I _{PD}	Power-down current:	See notes 1 and 4; 2 V < V _{PD} < V _{DD} max			
	P83(0)C552xBx P83(0)C552xFx			50 50	μA μA
	P83(0)C552xHx			150	μA
Inputs					
V _{IL}	Input low voltage, except \overline{EA} , P1.6, P1.7		-0.5	0.2V _{DD} -0.1	V
V _{IL1}	Input low voltage to \overline{EA}		-0.5	0.2V _{DD} -0.3	V
V _{IL2}	Input low voltage to P1.6/SCL, P1.7/SDA ⁵		-0.5	0.3V _{DD}	V
V _{IH}	Input high voltage, except XTAL1, RST, P1.6/SCL, P1.7/SDA		0.2V _{DD} +0.9	V _{DD} +0.5	V
V _{IH1}	Input high voltage, XTAL1, RST		0.7V _{DD}	V _{DD} +0.5	V
V _{IH2}	Input high voltage, P1.6/SCL, P1.7/SDA ⁵		0.7V _{DD}	6.0	V
I _{IL}	Logical 0 input current, ports 1, 2, 3, 4, except P1.6, P1.7	V _{IN} = 0.45 V		-50	μA
I _{TL}	Logical 1-to-0 transition current, ports 1, 2, 3, 4, except P1.6, P1.7	See note 6		-650	μA
±I _{IL1}	Input leakage current, port 0, \overline{EA} , STADC, \overline{EW}	0.45 V < V _I < V _{DD}		10	μA
±I _{IL2}	Input leakage current, P1.6/SCL, P1.7/SDA	0 V < V _I < 6 V 0 V < V _{DD} < 5.5 V		10	μA
±I _{IL3}	Input leakage current, port 5	0.45 V < V _I < V _{DD}		1	μA
Outputs					
V _{OL}	Output low voltage, ports 1, 2, 3, 4, except P1.6, P1.7	I _{OL} = 1.6mA ⁷		0.45	V
V _{OL1}	Output low voltage, port 0, ALE, PSEN, PWM0, PWM1	I _{OL} = 3.2mA ⁷		0.45	V
V _{OL2}	Output low voltage, P1.6/SCL, P1.7/SDA	I _{OL} = 3.0mA ⁷		0.4	V
V _{OH}	Output high voltage, ports 1, 2, 3, 4, except P1.6/SCL, P1.7/SDA	-I _{OH} = 60μA	2.4		V
		-I _{OH} = 25μA	0.75V _{DD}		V
		-I _{OH} = 10μA	0.9V _{DD}		V
V _{OH1}	Output high voltage (port 0 in external bus mode, ALE, PSEN, PWM0, PWM1) ⁸	-I _{OH} = 400μA	2.4		V
		-I _{OH} = 150μA	0.75V _{DD}		V
		-I _{OH} = 40μA	0.9V _{DD}		V
V _{OH2}	Output high voltage (RST)	-I _{OH} = 400μA	2.4		V
		-I _{OH} = 120μA	0.8V _{DD}		V
R _{RST}	Internal reset pull-down resistor		50	150	kΩ
C _{IO}	Pin capacitance	Test freq = 1 MHz, T _{amb} = 25 °C		10	pF

Single-chip 8-bit microcontroller with 10-bit A/D, capture/compare timer, high-speed outputs, PWM

80C552/83C552

DC ELECTRICAL CHARACTERISTICS (Continued)

SYMBOL	PARAMETER	TEST CONDITIONS	LIMITS		UNIT
			MIN	MAX	
Analog Inputs					
AI _{DD}	Analog supply current: operating: (16 MHz) Analog supply current: operating: (24 MHz)	Port 5 = 0 to AV _{DD} Port 5 = 0 to AV _{DD}		1.2 1.0	mA mA
AI _{ID}	Idle mode: P83(0)C552EBx P83(0)C552EFx P83(0)C552EHx P83(0)C552IBx P83(0)C552IFx			50 50 100 50 50	μA μA μA μA μA
AI _{PD}	Power-down mode: P83(0)C552xBx P83(0)C552xFx P83(0)C552xHx	2 V < AV _{PD} < AV _{DD} max		50 50 100	μA μA μA
AV _{IN}	Analog input voltage		AV _{SS} -0.2	AV _{DD} +0.2	V
AV _{REF}	Reference voltage: AV _{REF-} AV _{REF+}		AV _{SS} -0.2	AV _{DD} +0.2	V V
R _{REF}	Resistance between AV _{REF+} and AV _{REF-}		10	50	kΩ
C _{IA}	Analog input capacitance			15	pF
t _{ADS}	Sampling time			8t _{CY}	μs
t _{ADC}	Conversion time (including sampling time)			50t _{CY}	μs
DL _e	Differential non-linearity ^{10, 11, 12}			±1	LSB
IL _e	Integral non-linearity ^{10, 13}			±2	LSB
OS _e	Offset error ^{10, 14}			±2	LSB
G _e	Gain error ^{10, 15}			±0.4	%
A _e	Absolute voltage error ^{10, 16}			±3	LSB
M _{CTC}	Channel to channel matching			±1	LSB
C _t	Crosstalk between inputs of port 5 ¹⁷	0-100kHz		-60	dB

NOTES FOR DC ELECTRICAL CHARACTERISTICS:

- See Figures 10 through 15 for I_{DD} test conditions.
- The operating supply current is measured with all output pins disconnected; XTAL1 driven with t_r = t_f = 10 ns; V_{IL} = V_{SS} + 0.5 V; V_{IH} = V_{DD} - 0.5 V; XTAL2 not connected; EA = RST = Port 0 = EW = V_{DD}; STADC = V_{SS}.
- The idle mode supply current is measured with all output pins disconnected; XTAL1 driven with t_r = t_f = 10 ns; V_{IL} = V_{SS} + 0.5 V; V_{IH} = V_{DD} - 0.5 V; XTAL2 not connected; Port 0 = EW = V_{DD}; EA = RST = STADC = V_{SS}.
- The power-down current is measured with all output pins disconnected; XTAL2 not connected; Port 0 = EW = V_{DD}; EA = RST = STADC = XTAL1 = V_{SS}.
- The input threshold voltage of P1.6 and P1.7 (SIO1) meets the I²C specification, so an input voltage below 1.5 V will be recognized as a logic 0 while an input voltage above 3.0 V will be recognized as a logic 1.
- Pins of ports 1 (except P1.6, P1.7), 2, 3, and 4 source a transition current when they are being externally driven from 1 to 0. The transition current reaches its maximum value when V_{IN} is approximately 2 V.
- Capacitive loading on ports 0 and 2 may cause spurious noise to be superimposed on the V_{OLs} of ALE and ports 1 and 3. The noise is due to external bus capacitance discharging into the port 0 and port 2 pins when these pins make 1-to-0 transitions during bus operations. In the worst cases (capacitive loading > 100 pF), the noise pulse on the ALE pin may exceed 0.8 V. In such cases, it may be desirable to qualify ALE with a Schmitt Trigger, or use an address latch with a Schmitt Trigger STROBE input. I_{OL} can exceed these conditions provided that no single output sinks more than 5mA and no more than two outputs exceed the test conditions.
- Capacitive loading on ports 0 and 2 may cause the V_{OH} on ALE and PSEN to momentarily fall below the 0.9 V_{DD} specification when the address bits are stabilizing.
- The following condition must not be exceeded: V_{DD} - 0.2 V < AV_{DD} < V_{DD} + 0.2 V.
- Conditions: AV_{REF-} = 0 V; AV_{DD} = 5.0 V, AV_{REF+} (80C552, 83C552) = 5.12 V. ADC is monotonic with no missing codes. Measurement by continuous conversion of AV_{IN} = -20 mV to 5.12 V in steps of 0.5 mV.
- The differential non-linearity (DL_e) is the difference between the actual step width and the ideal step width. (See Figure 1.)
- The ADC is monotonic; there are no missing codes.
- The integral non-linearity (IL_e) is the peak difference between the center of the steps of the actual and the ideal transfer curve after appropriate adjustment of gain and offset error. (See Figure 1.)

Single-chip 8-bit microcontroller with 10-bit A/D, capture/compare timer, high-speed outputs, PWM

80C552/83C552

- 14. The offset error (OS_e) is the absolute difference between the straight line which fits the actual transfer curve (after removing gain error), and a straight line which fits the ideal transfer curve. (See Figure 1.)
- 15. The gain error (G_e) is the relative difference in percent between the straight line fitting the actual transfer curve (after removing offset error), and the straight line which fits the ideal transfer curve. Gain error is constant at every point on the transfer curve. (See Figure 1.)
- 16. The absolute voltage error (A_e) is the maximum difference between the center of the steps of the actual transfer curve of the non-calibrated ADC and the ideal transfer curve.
- 17. This should be considered when both analog and digital signals are simultaneously input to port 5.

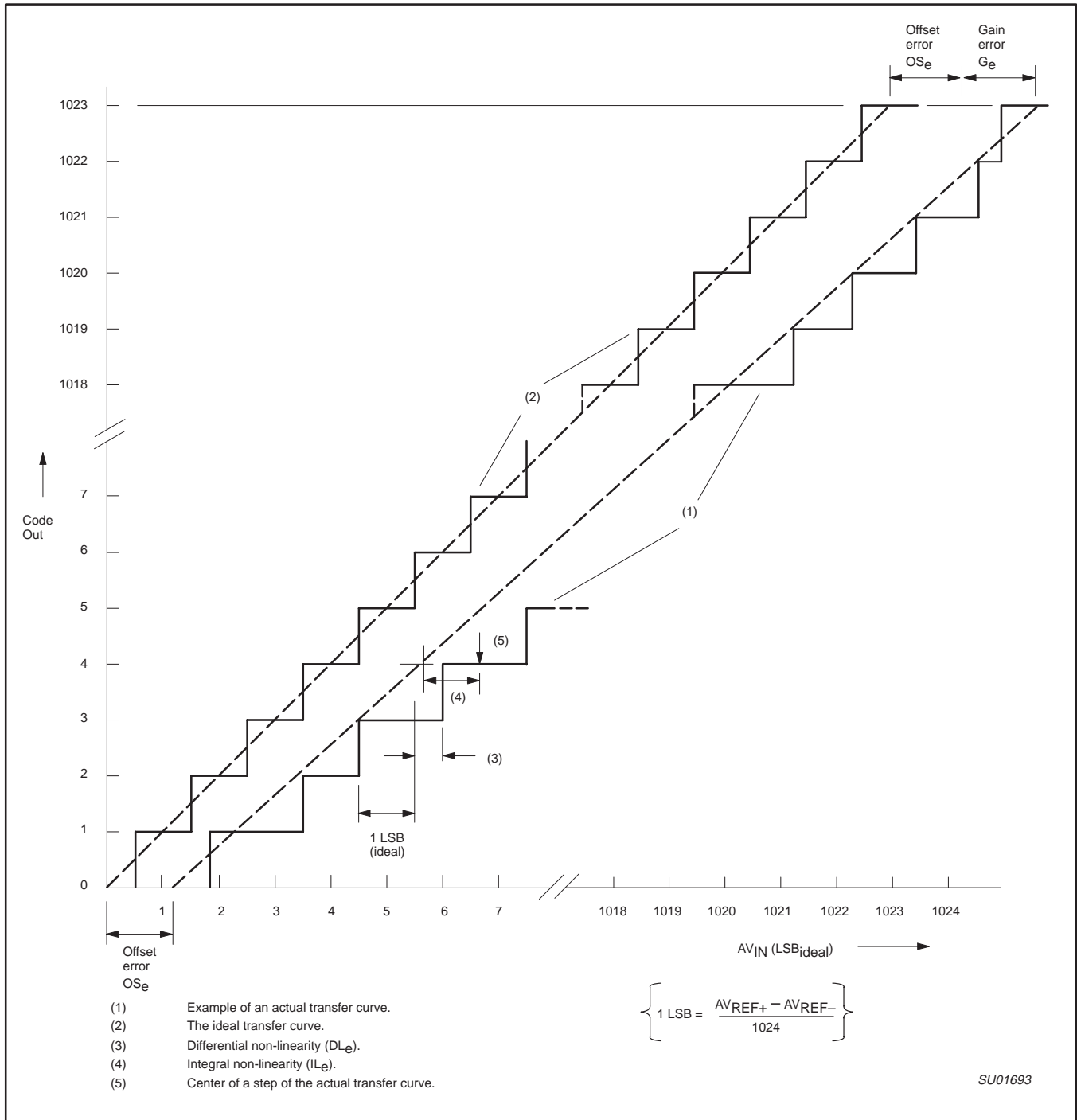

Figure 1. ADC Conversion Characteristic

Single-chip 8-bit microcontroller with 10-bit A/D, capture/compare timer, high-speed outputs, PWM

80C552/83C552

AC ELECTRICAL CHARACTERISTICS^{1, 2}

16 MHz version

SYMBOL	FIGURE	PARAMETER	16 MHz CLOCK		VARIABLE CLOCK		UNIT
			MIN	MAX	MIN	MAX	
$1/t_{CLCL}$	2	Oscillator frequency			3.5	16	MHz
t_{LHLL}	2	ALE pulse width	85		$2t_{CLCL}-40$		ns
t_{AVLL}	2	Address valid to ALE low	8		$t_{CLCL}-55$		ns
t_{LLAX}	2	Address hold after ALE low	28		$t_{CLCL}-35$		ns
t_{LLIV}	2	ALE low to valid instruction in		150		$4t_{CLCL}-100$	ns
t_{LLPL}	2	ALE low to PSEN low	23		$t_{CLCL}-40$		ns
t_{PLPH}	2	PSEN pulse width	143		$3t_{CLCL}-45$		ns
t_{PLIV}	2	PSEN low to valid instruction in		83		$3t_{CLCL}-105$	ns
t_{PXIX}	2	Input instruction hold after PSEN	0		0		ns
t_{PXIZ}	2	Input instruction float after PSEN		38		$t_{CLCL}-25$	ns
t_{AVIV}	2	Address to valid instruction in		208		$5t_{CLCL}-105$	ns
t_{PLAZ}	2	PSEN low to address float		10		10	ns
Data Memory							
t_{RLRH}	3	RD pulse width	275		$6t_{CLCL}-100$		ns
t_{WLWH}	4	WR pulse width	275		$6t_{CLCL}-100$		ns
t_{RLDV}	3	RD low to valid data in		148		$5t_{CLCL}-165$	ns
t_{RHDX}	3	Data hold after RD	0		0		ns
t_{RHDZ}	3	Data float after RD		55		$2t_{CLCL}-70$	ns
t_{LLDV}	3	ALE low to valid data in		350		$8t_{CLCL}-150$	ns
t_{AVDV}	3	Address to valid data in		398		$9t_{CLCL}-165$	ns
t_{LLWL}	3, 4	ALE low to RD or WR low	138	238	$3t_{CLCL}-50$	$3t_{CLCL}+50$	ns
t_{AVWL}	3, 4	Address valid to WR low or RD low	120		$4t_{CLCL}-130$		ns
t_{QVWX}	4	Data valid to WR transition	3		$t_{CLCL}-60$		ns
t_{DW}	4	Data before WR	288		$7t_{CLCL}-150$		ns
t_{WHQX}	4	Data hold after WR	13		$t_{CLCL}-50$		ns
t_{RLAZ}	3	RD low to address float		0		0	ns
t_{WHLH}	3, 4	RD or WR high to ALE high	23	103	$t_{CLCL}-40$	$t_{CLCL}+40$	ns
External Clock							
t_{CHCX}	5	High time ⁴	20		20		ns
t_{CLCX}	5	Low time ⁴	20		20		ns
t_{CLCH}	5	Rise time ⁴		20		20	ns
t_{CHCL}	5	Fall time ⁴		20		20	ns
Serial Timing – Shift Register Mode⁴ (Test Conditions: $T_{amb} = 0\text{ }^{\circ}\text{C}$ to $+70\text{ }^{\circ}\text{C}$; $V_{SS} = 0\text{ V}$; Load Capacitance = 80 pF)							
t_{XLXL}	6	Serial port clock cycle time	0.75		$12t_{CLCL}$		μs
t_{QVXH}	6	Output data setup to clock rising edge	492		$10t_{CLCL}-133$		ns
t_{XHQX}	6	Output data hold after clock rising edge	8		$2t_{CLCL}-117$		ns
t_{XHDX}	6	Input data hold after clock rising edge	0		0		ns
t_{XHDV}	6	Clock rising edge to input data valid		492		$10t_{CLCL}-133$	ns

NOTES:

- Parameters are valid over operating temperature range unless otherwise specified.
- Load capacitance for port 0, ALE, and PSEN = 100 pF, load capacitance for all other outputs = 80 pF.
- $t_{CLCL} = 1/f_{OSC}$ = one oscillator clock period.
 $t_{CLCL} = 83.3\text{ ns}$ at $f_{OSC} = 12\text{ MHz}$.
 $t_{CLCL} = 62.5\text{ ns}$ at $f_{OSC} = 16\text{ MHz}$.
- These values are characterized but not 100% production tested.

Single-chip 8-bit microcontroller with 10-bit A/D, capture/compare timer, high-speed outputs, PWM

80C552/83C552

AC ELECTRICAL CHARACTERISTICS (Continued)^{1, 2}

24 MHz version

SYMBOL	FIGURE	PARAMETER	24 MHz CLOCK		VARIABLE CLOCK		UNIT
			MIN	MAX	MIN	MAX	
$1/t_{CLCL}$	2	Oscillator frequency			3.5	24	MHz
t_{LHLL}	2	ALE pulse width	43		$2t_{CLCL}-40$		ns
t_{AVLL}	2	Address valid to ALE low	17		$t_{CLCL}-25$		ns
t_{LLAX}	2	Address hold after ALE low	17		$t_{CLCL}-25$		ns
t_{LLIV}	2	ALE low to valid instruction in		102		$4t_{CLCL}-65$	ns
t_{LLPL}	2	ALE low to \overline{PSEN} low	17		$t_{CLCL}-25$		ns
t_{PLPH}	2	\overline{PSEN} pulse width	80		$3t_{CLCL}-45$		ns
t_{PLIV}	2	\overline{PSEN} low to valid instruction in		65		$3t_{CLCL}-60$	ns
t_{PXIX}	2	Input instruction hold after \overline{PSEN}	0		0		ns
t_{PXIZ}	2	Input instruction float after \overline{PSEN}		17		$t_{CLCL}-25$	ns
t_{AVIV}	2	Address to valid instruction in		128		$5t_{CLCL}-80$	ns
t_{PLAZ}	2	\overline{PSEN} low to address float		10		10	ns
Data Memory							
t_{RLRH}	3	\overline{RD} pulse width	150		$6t_{CLCL}-100$		ns
t_{WLWH}	4	\overline{WR} pulse width	150		$6t_{CLCL}-100$		ns
t_{RLDV}	3	\overline{RD} low to valid data in		118		$5t_{CLCL}-90$	ns
t_{RHDX}	3	Data hold after \overline{RD}	0		0		ns
t_{RHDX}	3	Data float after \overline{RDx}		55		$2t_{CLCL}-28$	ns
t_{LLDV}	3	ALE low to valid data in		183		$8t_{CLCL}-150$	ns
t_{AVDV}	3	Address to valid data in		210		$9t_{CLCL}-165$	ns
t_{LLWL}	3, 4	ALE low to \overline{RD} or \overline{WR} low	75	175	$3t_{CLCL}-50$	$3t_{CLCL}+50$	ns
t_{AVWL}	3, 4	Address valid to \overline{WR} low or \overline{RD} low	92		$4t_{CLCL}-75$		ns
t_{QVWX}	4	Data valid to \overline{WR} transition	12		$t_{CLCL}-30$		ns
t_{DW}	4	Data before \overline{WR}	162		$7t_{CLCL}-130$		ns
t_{WHQX}	4	Data hold after \overline{WR}	17		$t_{CLCL}-25$		ns
t_{RLAZ}	3	\overline{RD} low to address float		0		0	ns
t_{WHLH}	3, 4	\overline{RD} or \overline{WR} high to ALE high	17	67	$t_{CLCL}-25$	$t_{CLCL}+25$	ns
External Clock							
t_{CHCX}	5	High time ³	17		17		ns
t_{CLCX}	5	Low time ³	17		17		ns
t_{CLCH}	5	Rise time ³		5		20	ns
t_{CHCL}	5	Fall time ³		5		20	ns
Serial Timing – Shift Register Mode³ (Test Conditions: $T_{amb} = 0\text{ }^{\circ}\text{C}$ to $+70\text{ }^{\circ}\text{C}$; $V_{SS} = 0\text{ V}$; Load Capacitance = 80 pF)							
t_{XLXL}	6	Serial port clock cycle time	0.5		$12t_{CLCL}$		μs
t_{QVXH}	6	Output data setup to clock rising edge	283		$10t_{CLCL}-133$		ns
t_{XHQX}	6	Output data hold after clock rising edge	23		$2t_{CLCL}-60$		ns
t_{XHDX}	6	Input data hold after clock rising edge	0		0		ns
t_{XHDX}	6	Clock rising edge to input data valid		283		$10t_{CLCL}-133$	ns

NOTES:

- Parameters are valid over operating temperature range unless otherwise specified.
- Load capacitance for port 0, ALE, and \overline{PSEN} = 100 pF, load capacitance for all other outputs = 80 pF.
- These values are characterized but not 100% production tested.
- $t_{CLCL} = 1/f_{OSC}$ = one oscillator clock period.
 $t_{CLCL} = 41.7\text{ ns}$ at $f_{OSC} = 24\text{ MHz}$.

Single-chip 8-bit microcontroller with 10-bit A/D, capture/compare timer, high-speed outputs, PWM

80C552/83C552

AC ELECTRICAL CHARACTERISTICS (Continued)

SYMBOL	PARAMETER	INPUT	OUTPUT
I²C Interface (Refer to Figure 9)			
t _{HD;STA}	START condition hold time	≥ 14 t _{CLCL}	> 4.0 μs ¹
t _{LOW}	SCL low time	≥ 16 t _{CLCL}	> 4.7 μs ¹
t _{HIGH}	SCL high time	≥ 14 t _{CLCL}	> 4.0 μs ¹
t _{RC}	SCL rise time	≤ 1 μs	– ²
t _{FC}	SCL fall time	≤ 0.3 μs	< 0.3 μs ³
t _{SU;DAT1}	Data set-up time	≥ 250ns	> 20 t _{CLCL} – t _{RD}
t _{SU;DAT2}	SDA set-up time (before rep. START cond.)	≥ 250ns	> 1 μs ¹
t _{SU;DAT3}	SDA set-up time (before STOP cond.)	≥ 250ns	> 8 t _{CLCL}
t _{HD;DAT}	Data hold time	≥ 0ns	> 8 t _{CLCL} – t _{FC}
t _{SU;STA}	Repeated START set-up time	≥ 14 t _{CLCL}	> 4.7 μs ¹
t _{SU;STO}	STOP condition set-up time	≥ 14 t _{CLCL}	> 4.0 μs ¹
t _{BUF}	Bus free time	≥ 14 t _{CLCL}	> 4.7 μs ¹
t _{RD}	SDA rise time	≤ 1 μs	– ²
t _{FD}	SDA fall time	≤ 0.3 μs	< 0.3 μs ³

NOTES:

- At 100 kbit/s. At other bit rates this value is inversely proportional to the bit-rate of 100 kbit/s.
- Determined by the external bus-line capacitance and the external bus-line pull-resistor, this must be < 1 μs.
- Spikes on the SDA and SCL lines with a duration of less than 3 t_{CLCL} will be filtered out. Maximum capacitance on bus-lines SDA and SCL = 400 pF.
- t_{CLCL} = 1/f_{OSC} = one oscillator clock period at pin XTAL1. For 62 ns, 42 ns < t_{CLCL} < 285 ns (16 MHz, 24 MHz > f_{OSC} > 3.5 MHz) the SI01 interface meets the I²C-bus specification for bit-rates up to 100 kbit/s.

Single-chip 8-bit microcontroller with 10-bit A/D, capture/compare timer, high-speed outputs, PWM

80C552/83C552

EXPLANATION OF THE AC SYMBOLS

Each timing symbol has five characters. The first character is always 't' (= time). The other characters, depending on their positions, indicate the name of a signal or the logical status of that signal. The designations are:

- A – Address
- C – Clock
- D – Input data
- H – Logic level high
- I – Instruction (program memory contents)
- L – Logic level low, or ALE
- P – PSEN

- Q – Output data
- R – \overline{RD} signal
- t – Time
- V – Valid
- W – WR signal
- X – No longer a valid logic level
- Z – Float

Examples: t_{AVLL} = Time for address valid to ALE low.
 t_{LLPL} = Time for ALE low to PSEN low.

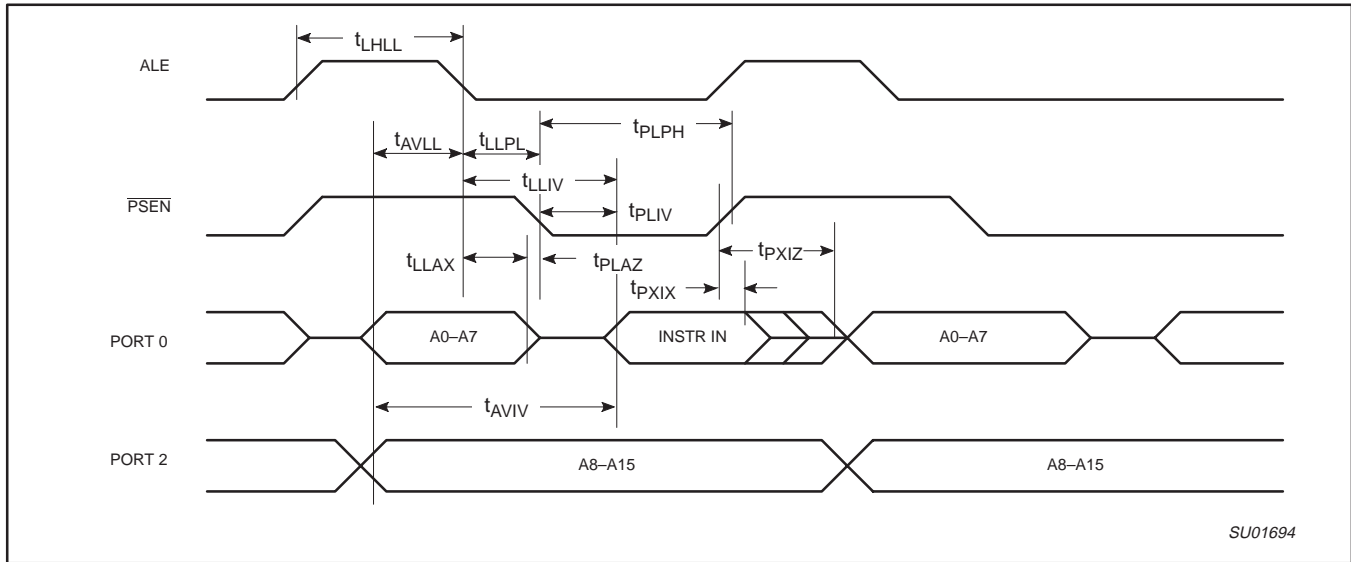

Figure 2. External Program Memory Read Cycle

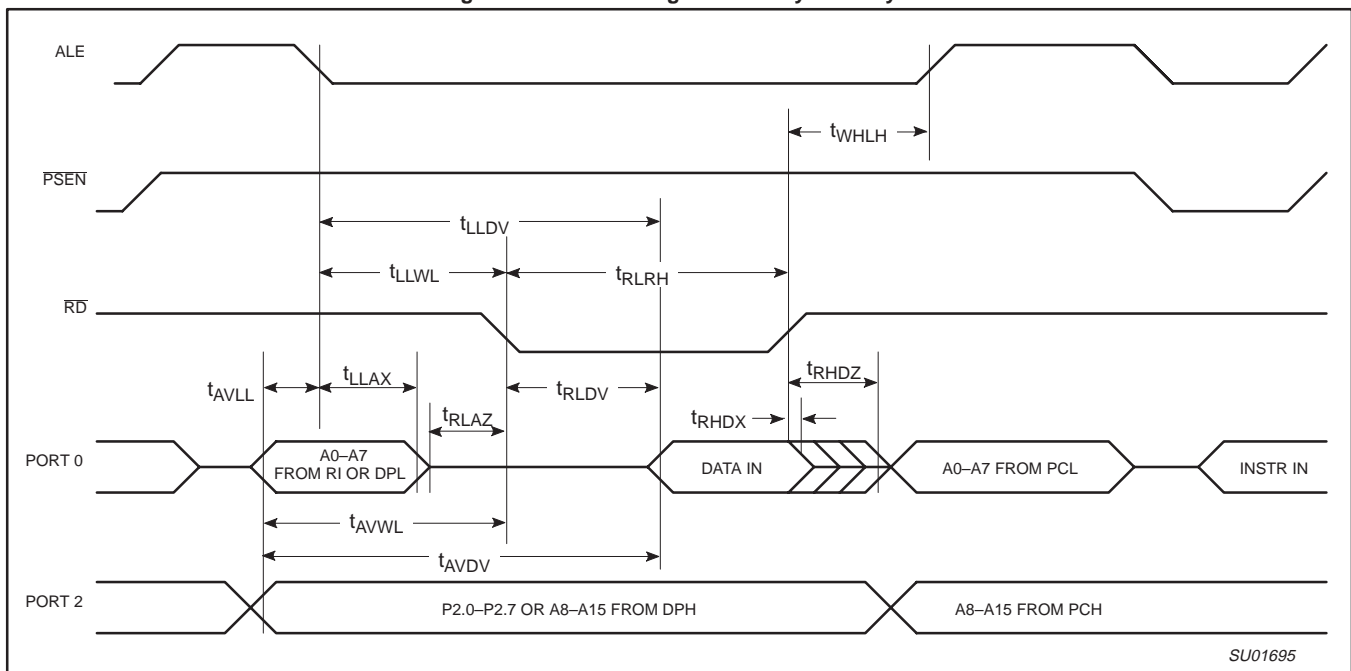

Figure 3. External Data Memory Read Cycle

Single-chip 8-bit microcontroller with 10-bit A/D, capture/compare timer, high-speed outputs, PWM

80C552/83C552

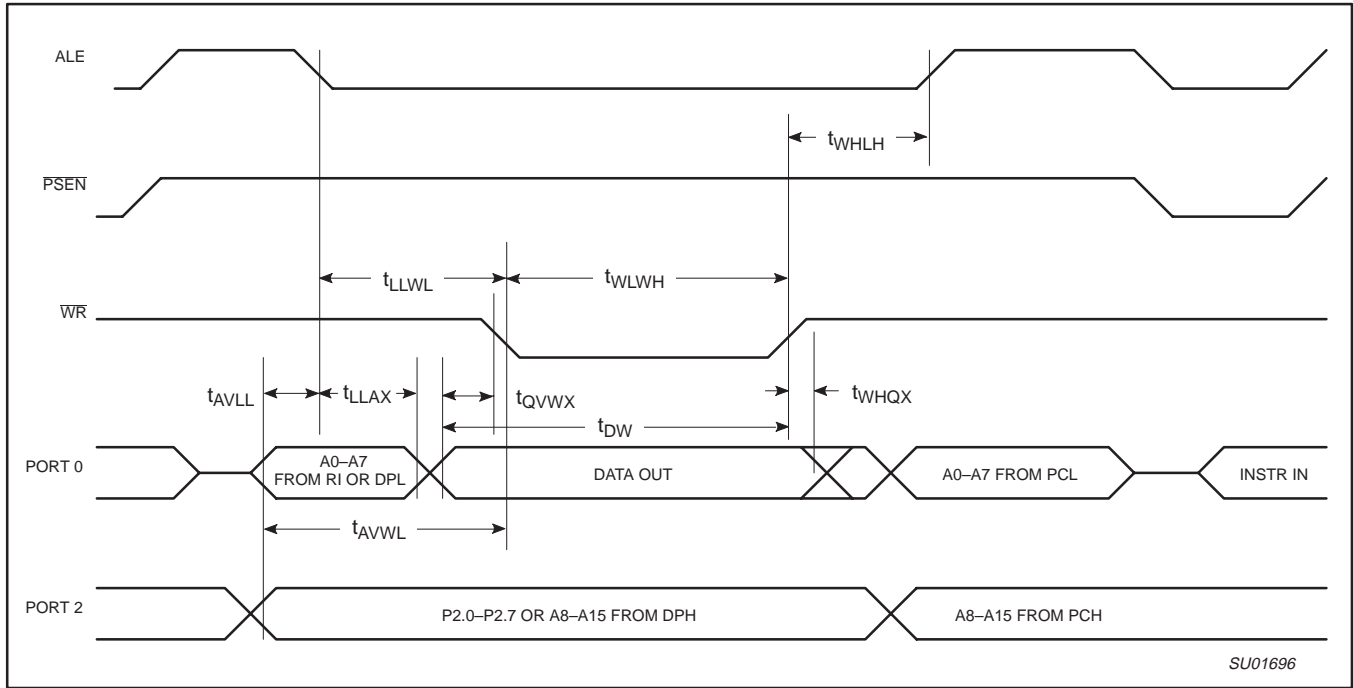

Figure 4. External Data Memory Write Cycle

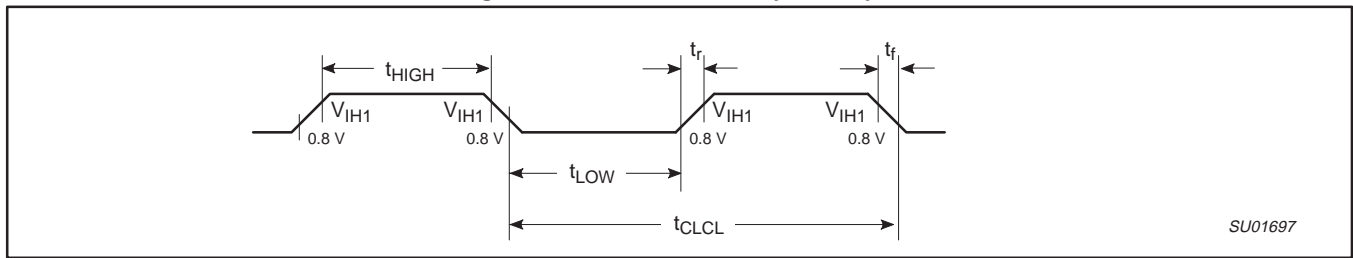

Figure 5. External Clock Drive XTAL1

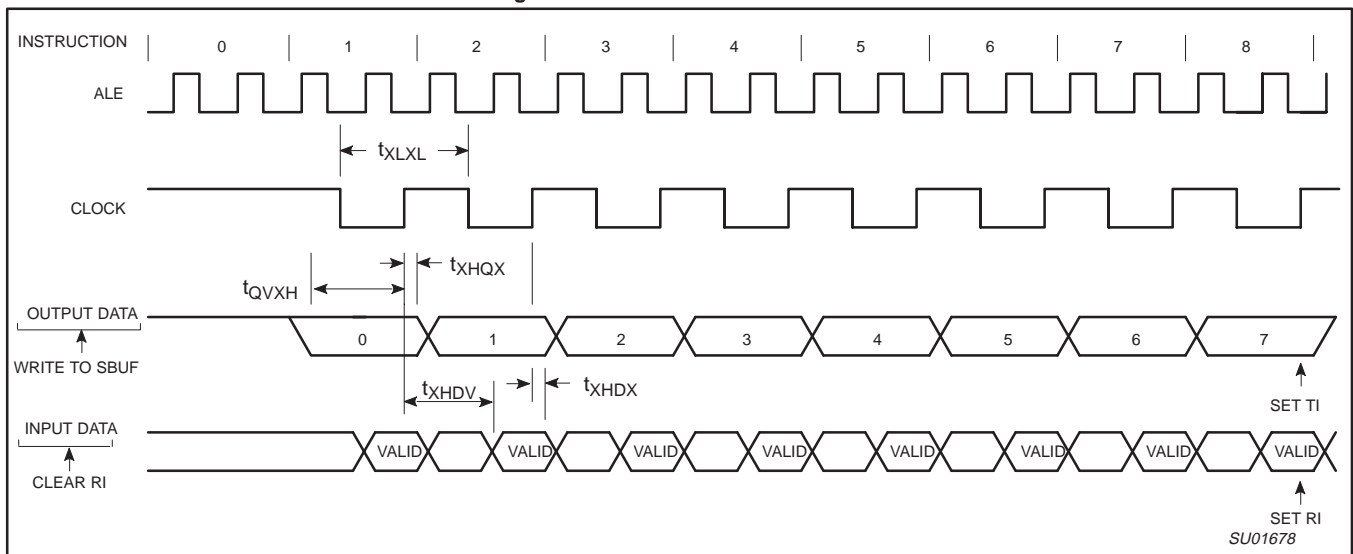

Figure 6. Shift Register Mode Timing

Single-chip 8-bit microcontroller with 10-bit A/D,
capture/compare timer, high-speed outputs, PWM

80C552/83C552

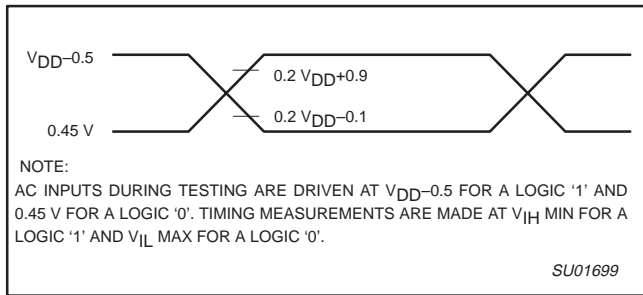

Figure 7. AC Testing Input/Output

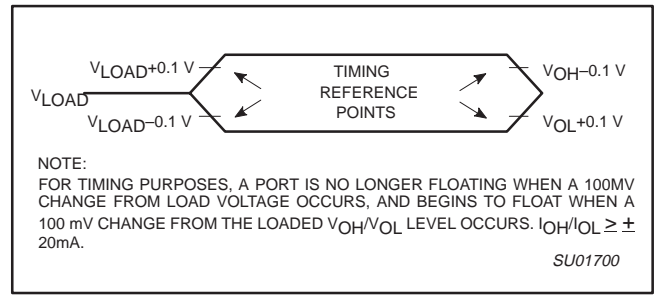

Figure 8. Float Waveform

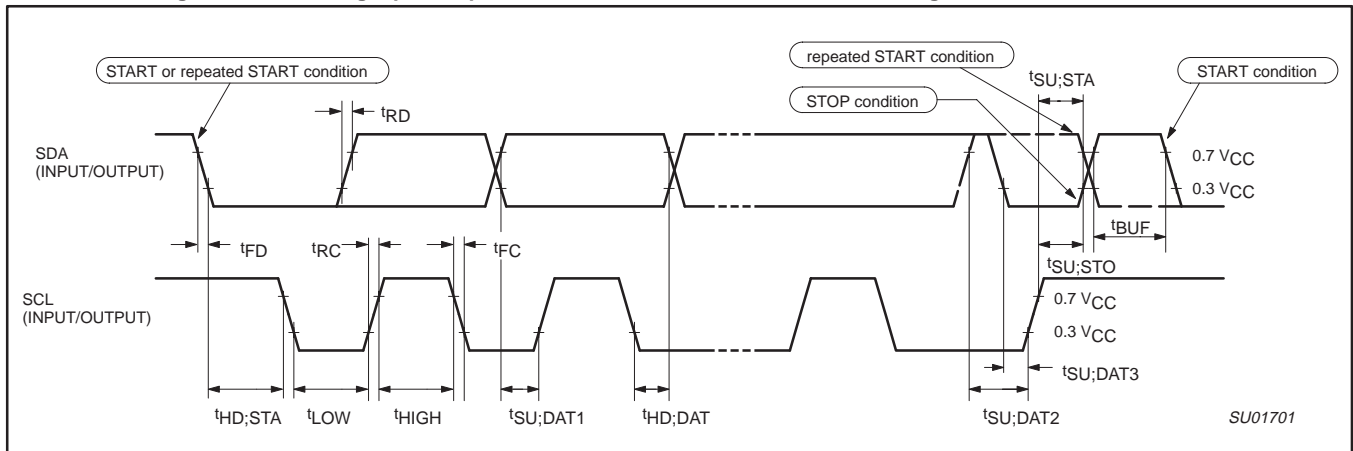

Figure 9. Timing SIO1 (I²C) Interface

Single-chip 8-bit microcontroller with 10-bit A/D,
capture/compare timer, high-speed outputs, PWM

80C552/83C552

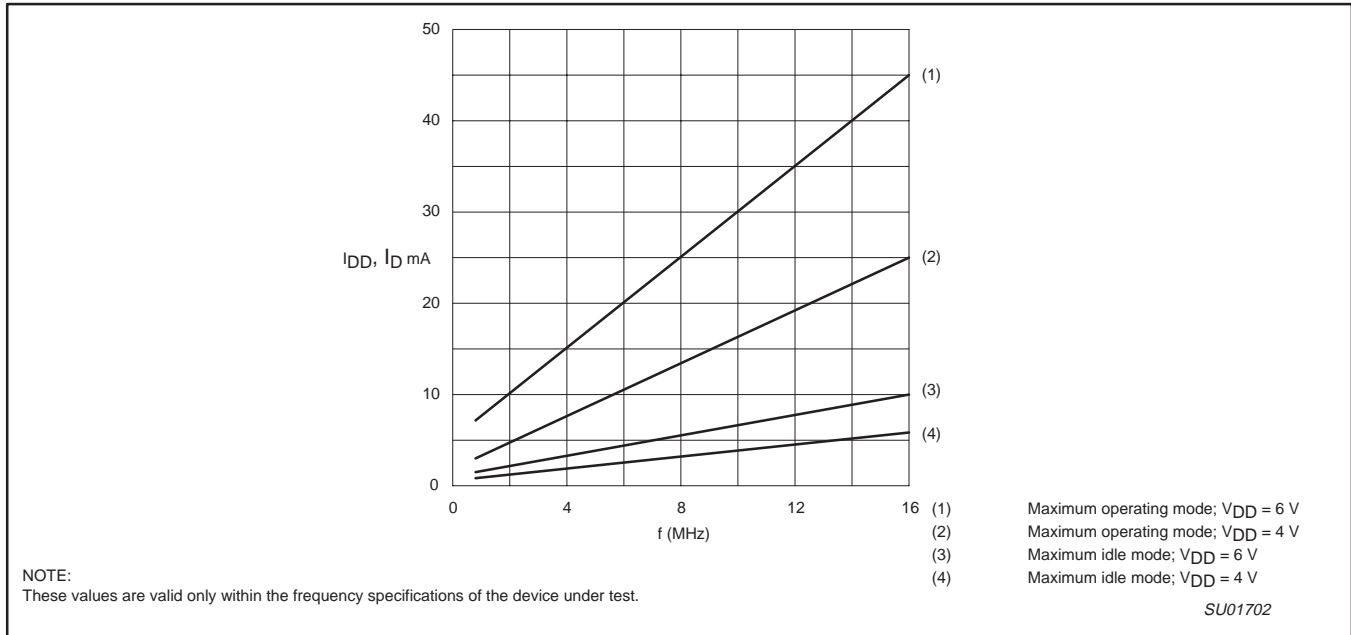

Figure 10. 16 MHz Version Supply Current (I_{DD}) as a Function of Frequency at XTAL1 (f_{OSC})

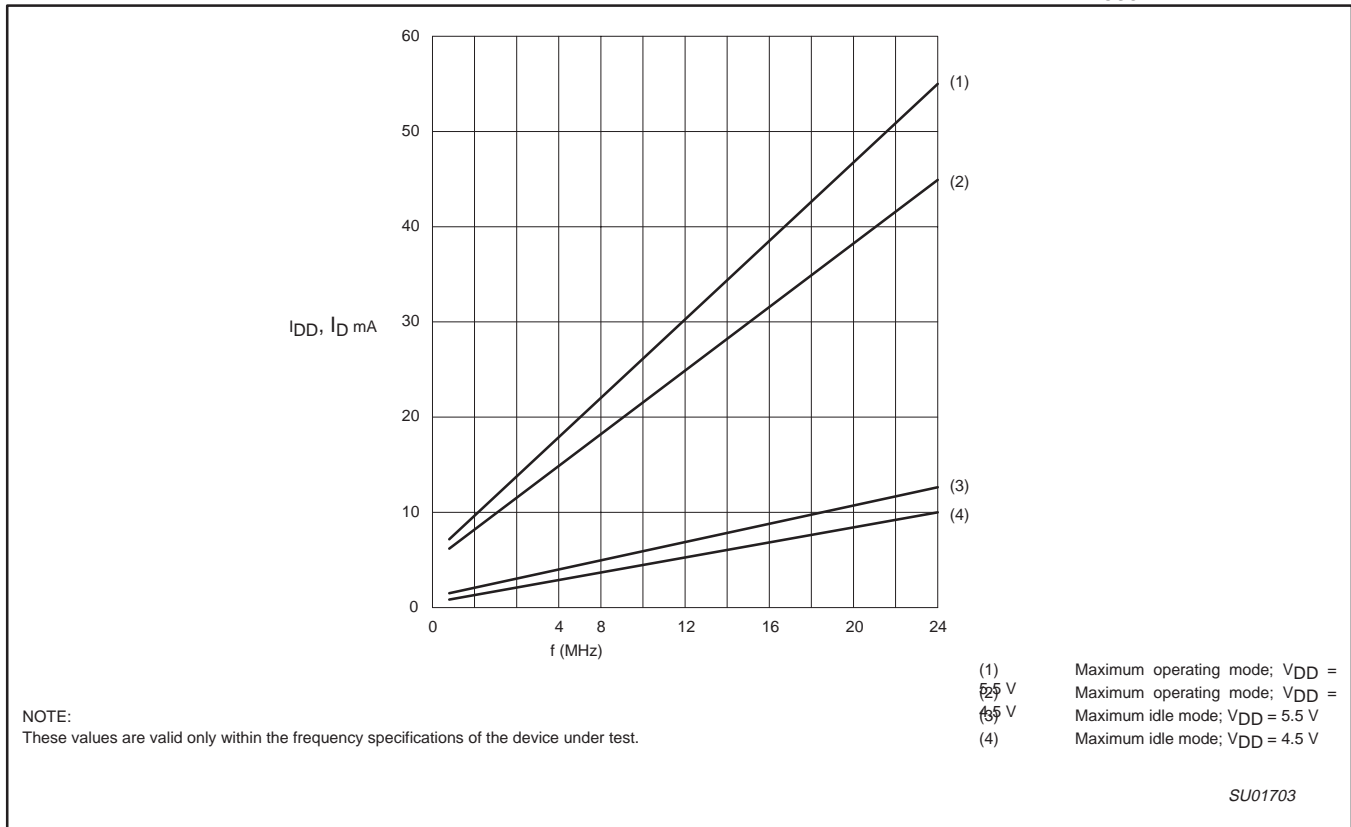

Figure 11. 24 MHz Version Supply Current (I_{DD}) as a Function of Frequency at XTAL1 (f_{OSC})

Single-chip 8-bit microcontroller with 10-bit A/D, capture/compare timer, high-speed outputs, PWM

80C552/83C552

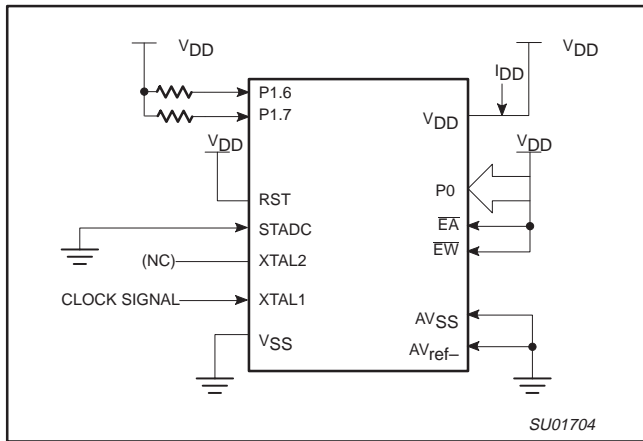

Figure 12. I_{DD} Test Condition, Active Mode
All other pins are disconnected¹

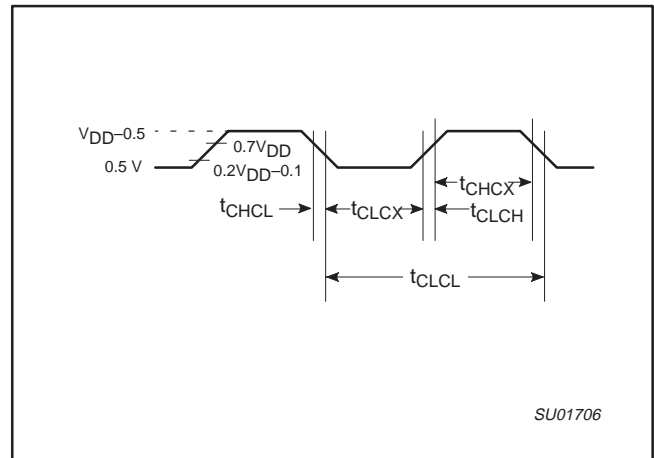

Figure 14. Clock Signal Waveform for I_{DD} Tests in Active and Idle Modes t_{CLCH} = t_{CHCL} = 5ns

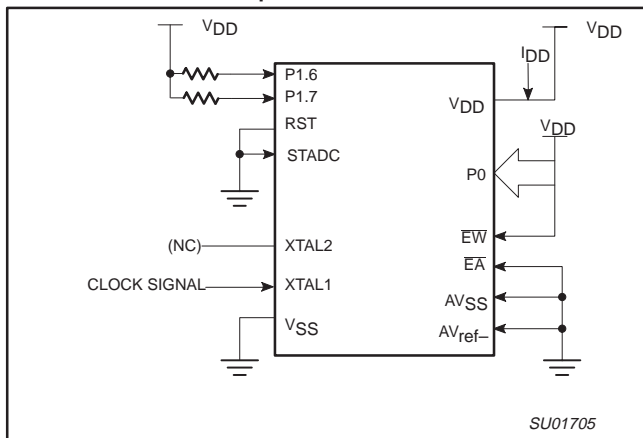

Figure 13. I_{DD} Test Condition, Idle Mode
All other pins are disconnected²

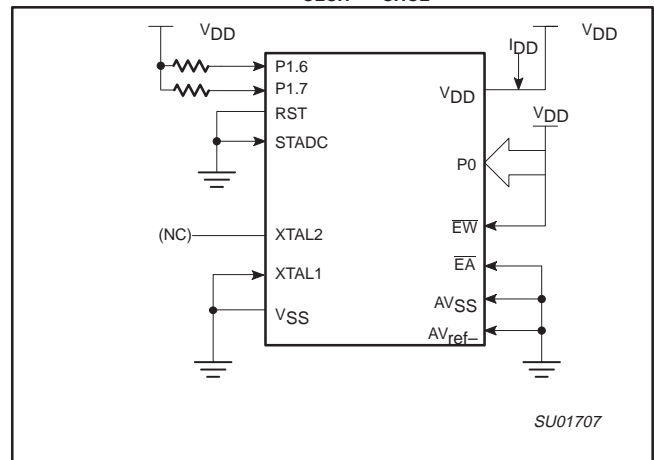

Figure 15. I_{DD} Test Condition, Power Down Mode
All other pins are disconnected. V_{DD} = 2 V to 5.5 V³

NOTES:

1. Active Mode:
 - a. The following pins must be forced to V_{DD}: \overline{EA} , RST, Port 0, and \overline{EW} .
 - b. The following pins must be forced to V_{SS}: STADC, AV_{SS}, and AV_{ref-}.
 - c. Ports 1.6 and 1.7 should be connected to V_{DD} through resistors of sufficiently high value such that the sink current into these pins cannot exceed the I_{OL1} spec of these pins.
 - d. The following pins must be disconnected: XTAL2 and all pins not specified above.
2. Idle Mode:
 - a. The following pins must be forced to V_{DD}: Port 0 and \overline{EW} .
 - b. The following pins must be forced to V_{SS}: RST, STADC, AV_{SS}, AV_{ref-}, and \overline{EA} .
 - c. Ports 1.6 and 1.7 should be connected to V_{DD} through resistors of sufficiently high value such that the sink current into these pins cannot exceed the I_{OL1} spec of these pins. These pins must not have logic 0 written to them prior to this measurement.
 - d. The following pins must be disconnected: XTAL2 and all pins not specified above.
3. Power Down Mode:
 - a. The following pins must be forced to V_{DD}: Port 0 and \overline{EW} .
 - b. The following pins must be forced to V_{SS}: RST, STADC, XTAL1, AV_{SS}, AV_{ref-}, and \overline{EA} .
 - c. Ports 1.6 and 1.7 should be connected to V_{DD} through resistors of sufficiently high value such that the sink current into these pins cannot exceed the I_{OL1} spec of these pins. These pins must not have logic 0 written to them prior to this measurement.
 - d. The following pins must be disconnected: XTAL2 and all pins not specified above.

Single-chip 8-bit microcontroller with 10-bit A/D, capture/compare timer, high-speed outputs, PWM

80C552/83C552

PLCC68: plastic leaded chip carrier; 68 leads

SOT188-2

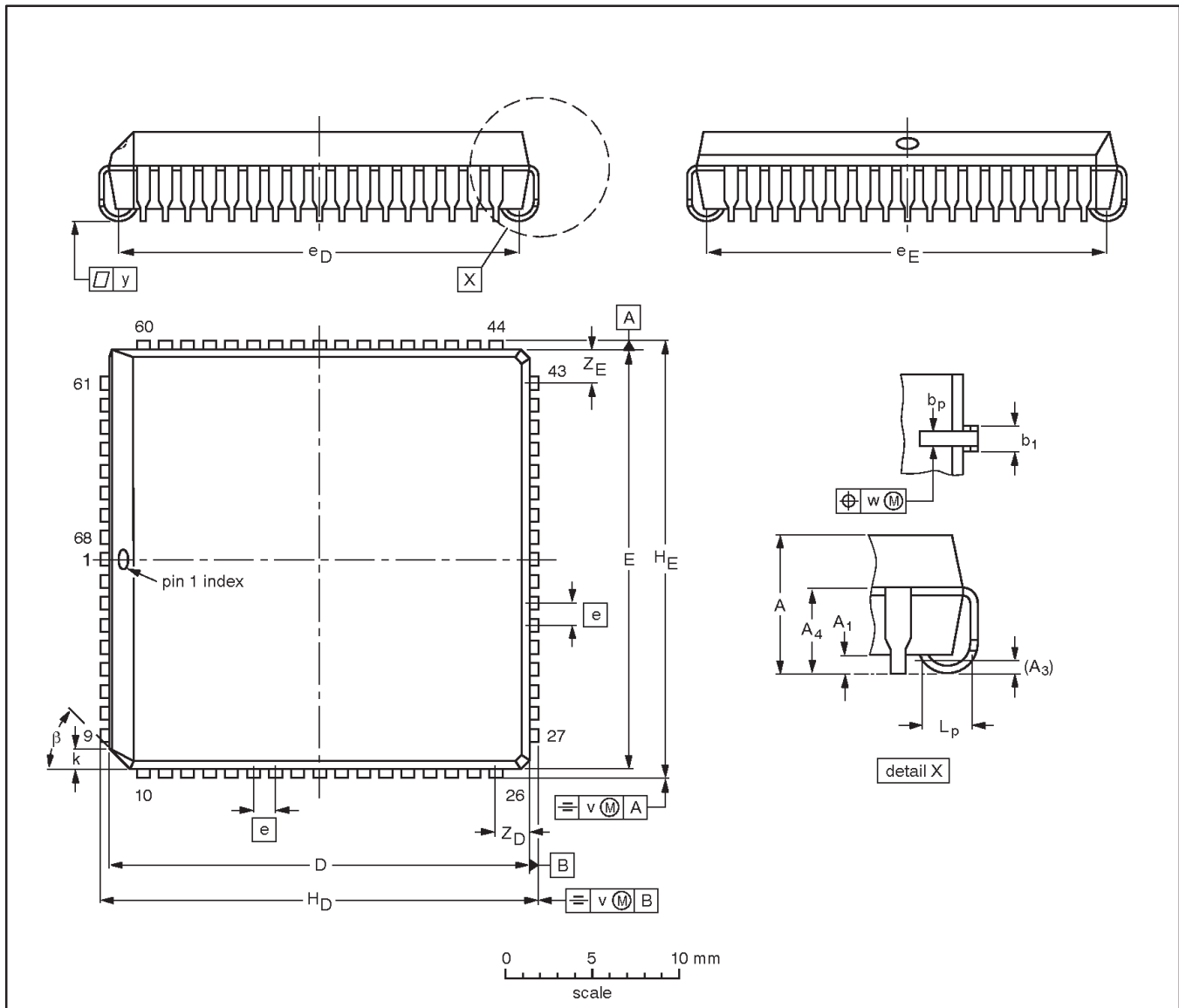

DIMENSIONS (mm dimensions are derived from the original inch dimensions)

UNIT	A	A ₁ min.	A ₃	A ₄ max.	b _p	b ₁	D ⁽¹⁾	E ⁽¹⁾	e	e _D	e _E	H _D	H _E	k	L _p	v	w	y	Z _D ⁽¹⁾ max.	Z _E ⁽¹⁾ max.	β
mm	4.57 4.19	0.51	0.25	3.3	0.53 0.33	0.81 0.66	24.33 24.13	24.33 24.13	1.27	23.62 22.61	23.62 22.61	25.27 25.02	25.27 25.02	1.22 1.07	1.44 1.02	0.18	0.18	0.1	2.16	2.16	45°
inches	0.180 0.165	0.02	0.01	0.13	0.021 0.013	0.032 0.026	0.958 0.950	0.958 0.950	0.05	0.93 0.89	0.93 0.89	0.995 0.985	0.995 0.985	0.048 0.042	0.057 0.040	0.007	0.007	0.004	0.085	0.085	

Note

1. Plastic or metal protrusions of 0.25 mm (0.01 inch) maximum per side are not included.

OUTLINE VERSION	REFERENCES				EUROPEAN PROJECTION	ISSUE DATE
	IEC	JEDEC	JEITA			
SOT188-2	112E10	MS-018	EDR-7319			99-12-27 01-11-14

Single-chip 8-bit microcontroller with 10-bit A/D, capture/compare timer, high-speed outputs, PWM

80C552/83C552

QFP80: plastic quad flat package; 80 leads (lead length 1.95 mm); body 14 x 20 x 2.8 mm **SOT318-2**

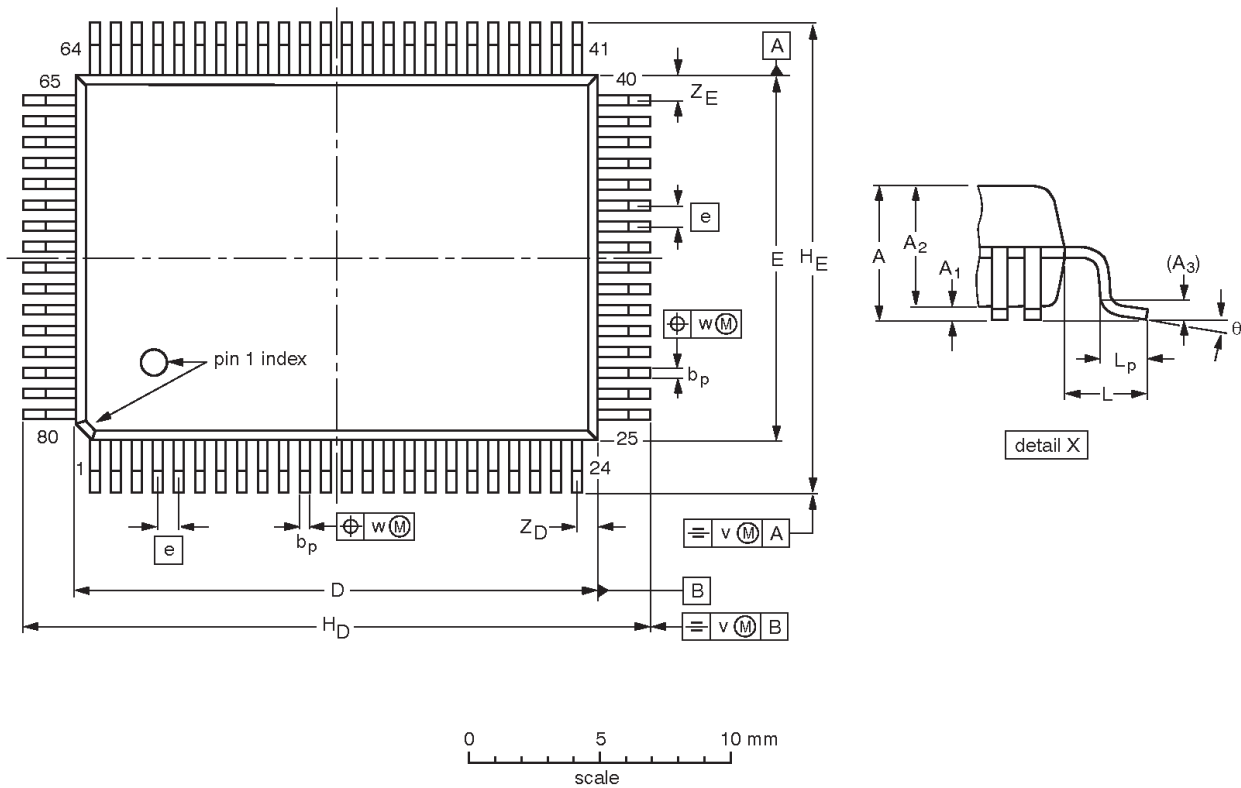
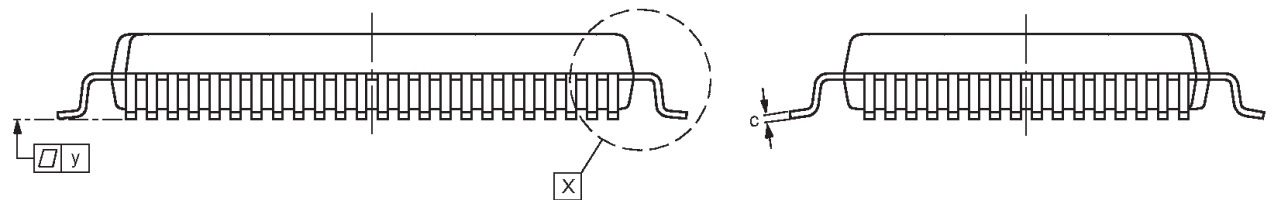

DIMENSIONS (mm are the original dimensions)

UNIT	A max.	A ₁	A ₂	A ₃	b _p	c	D ⁽¹⁾	E ⁽¹⁾	e	H _D	H _E	L	L _p	v	w	y	Z _D ⁽¹⁾	Z _E ⁽¹⁾	θ
mm	3.2	0.25 0.05	2.90 2.65	0.25	0.45 0.30	0.25 0.14	20.1 19.9	14.1 13.9	0.8	24.2 23.6	18.2 17.6	1.95	1.0 0.6	0.2	0.2	0.1	1.0 0.6	1.2 0.8	7° 0°

Note

1. Plastic or metal protrusions of 0.25 mm maximum per side are not included.

OUTLINE VERSION	REFERENCES				EUROPEAN PROJECTION	ISSUE DATE
	IEC	JEDEC	EIAJ			
SOT318-2		MO-112				97-08-01 99-12-27

Single-chip 8-bit microcontroller with 10-bit A/D, capture/compare timer, high-speed outputs, PWM

80C552/83C552



Purchase of Philips I²C components conveys a license under the Philips' I²C patent to use the components in the I²C system provided the system conforms to the I²C specifications defined by Philips. This specification can be ordered using the code 9398 393 40011.

Data sheet status

Data sheet status ^[1]	Product status ^[2]	Definitions
Objective data	Development	This data sheet contains data from the objective specification for product development. Philips Semiconductors reserves the right to change the specification in any manner without notice.
Preliminary data	Qualification	This data sheet contains data from the preliminary specification. Supplementary data will be published at a later date. Philips Semiconductors reserves the right to change the specification without notice, in order to improve the design and supply the best possible product.
Product data	Production	This data sheet contains data from the product specification. Philips Semiconductors reserves the right to make changes at any time in order to improve the design, manufacturing and supply. Changes will be communicated according to the Customer Product/Process Change Notification (CPCN) procedure SNW-SQ-650A.

[1] Please consult the most recently issued data sheet before initiating or completing a design.

[2] The product status of the device(s) described in this data sheet may have changed since this data sheet was published. The latest information is available on the Internet at URL <http://www.semiconductors.philips.com>.

Definitions

Short-form specification — The data in a short-form specification is extracted from a full data sheet with the same type number and title. For detailed information see the relevant data sheet or data handbook.

Limiting values definition — Limiting values given are in accordance with the Absolute Maximum Rating System (IEC 60134). Stress above one or more of the limiting values may cause permanent damage to the device. These are stress ratings only and operation of the device at these or at any other conditions above those given in the Characteristics sections of the specification is not implied. Exposure to limiting values for extended periods may affect device reliability.

Application information — Applications that are described herein for any of these products are for illustrative purposes only. Philips Semiconductors make no representation or warranty that such applications will be suitable for the specified use without further testing or modification.

Disclaimers

Life support — These products are not designed for use in life support appliances, devices or systems where malfunction of these products can reasonably be expected to result in personal injury. Philips Semiconductors customers using or selling these products for use in such applications do so at their own risk and agree to fully indemnify Philips Semiconductors for any damages resulting from such application.

Right to make changes — Philips Semiconductors reserves the right to make changes, without notice, in the products, including circuits, standard cells, and/or software, described or contained herein in order to improve design and/or performance. Philips Semiconductors assumes no responsibility or liability for the use of any of these products, conveys no license or title under any patent, copyright, or mask work right to these products, and makes no representations or warranties that these products are free from patent, copyright, or mask work right infringement, unless otherwise specified.

Contact information

For additional information please visit
<http://www.semiconductors.philips.com>. Fax: +31 40 27 24825

© Koninklijke Philips Electronics N.V. 2002
All rights reserved. Printed in U.S.A.

Date of release: 09-02

For sales offices addresses send e-mail to:
sales.addresses@www.semiconductors.philips.com

Document order number:

9397 750 10294

Let's make things better.

Mouser Electronics

Authorized Distributor

Click to View Pricing, Inventory, Delivery & Lifecycle Information:

[NXP:](#)

[P80C552EBA/08,512](#) [P80C552EBB/08,557](#) [P80C552EFA/08,512](#) [P80C552IBA/08,512](#) [P80C552IFA/08,512](#)
[P80C552EBA/08,518](#) [P80C552EFA/08,518](#) [P80C552EFB/08,557](#) [P80C552IBA/08,518](#)